

# 2021 CHAIRMAN'S AWARD SUBMISSION

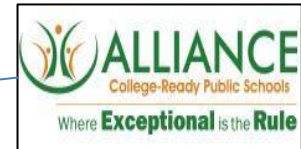

**FRC TEAM 980 THUNDERBOTS**

# STUDENT/MENTOR MAP

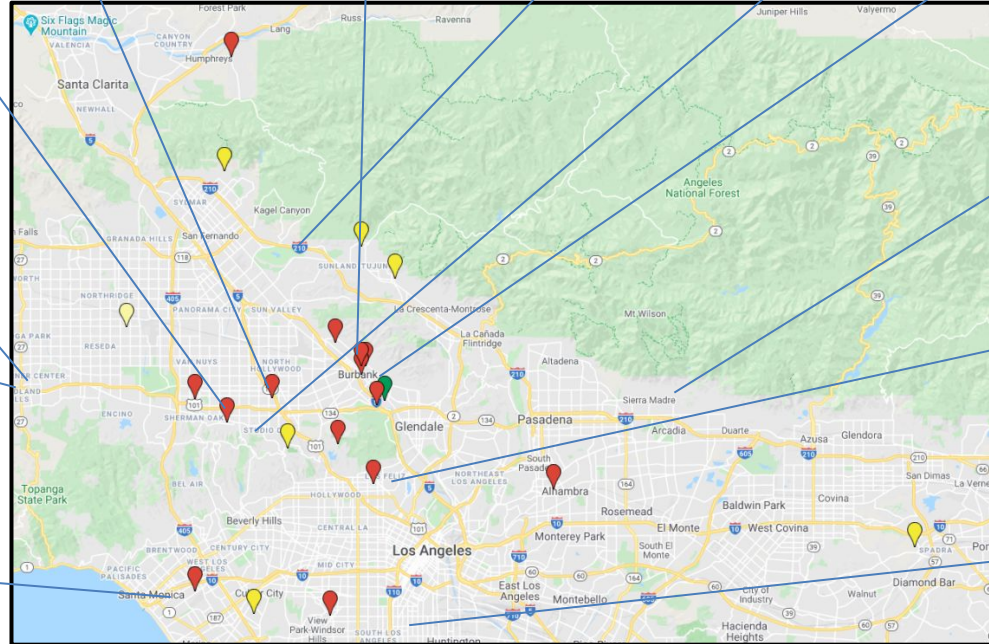

# MEMBERS' SCHOOLS

Berkeley  
UNIVERSITY OF CALIFORNIA

CORNELL  
UNIVERSITY



Caltech



PURDUE  
UNIVERSITY

Ucla



CAL POLY

UC San Diego



And also



SCIARC



# OUR BACKYARD NEEDS FIRST

**Before Team 980**



**After Team 980**

- **Open Houses**
- **LEGO RoboCamp**
- **FLL Team AstroTech**

# THE PIPELINE



&





- Created by Graduates
- Taught by Students
- Fundamentals of Robotics

# OUR RESPONSE TO THE PANDEMIC

The SoCal Makers COVID Response Team would like to thank...

**Major Donors**

The Brown Family

Michelle Cayton

FIRST Robotics Competition Team 980 – ThunderBots

Spyder3D, inc.

Boy Scout Troop 378

Girl Scout Troop 116

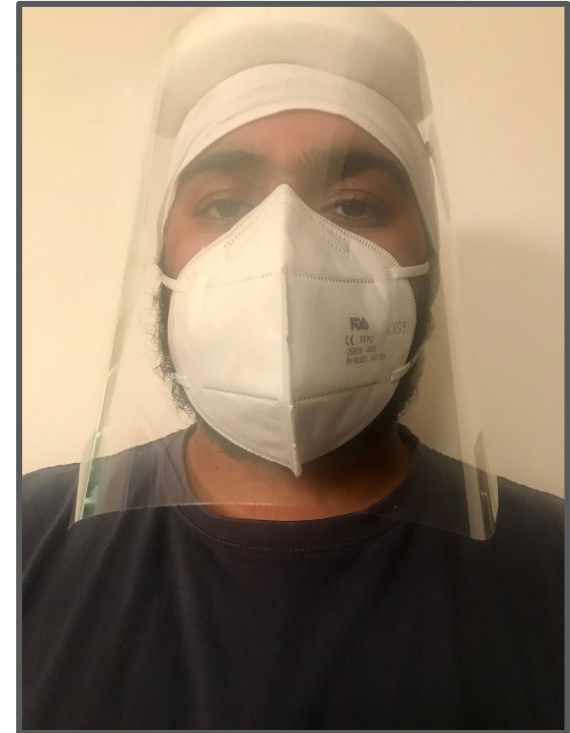

# TURNING LEGO ROBOCAMP VIRTUAL

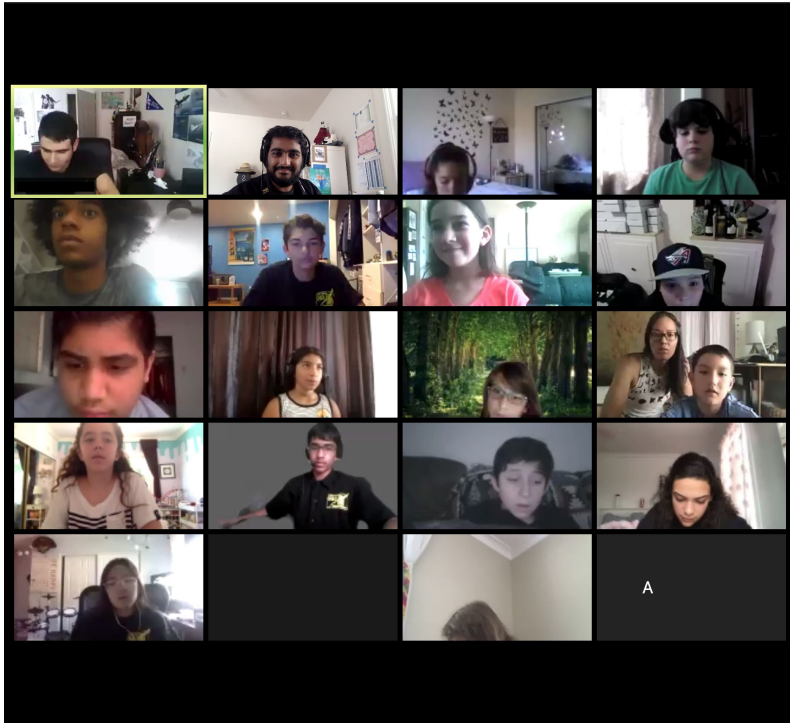

- Taught basics of
  - OnShape tutorials
  - EV3 Code lessons
  - Spaghetti Tower Structure
- Guest Speakers from STEM Careers
- No costs besides internet



# VIRTUAL BEACH BLITZ 2020

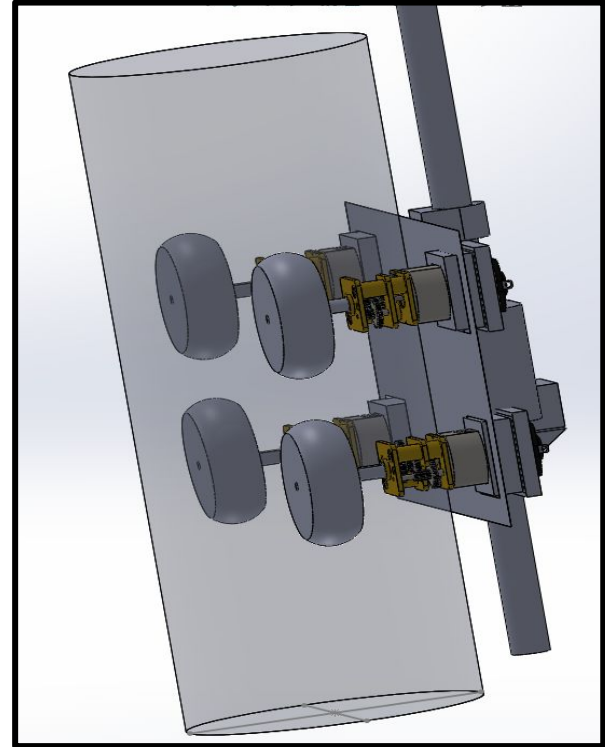
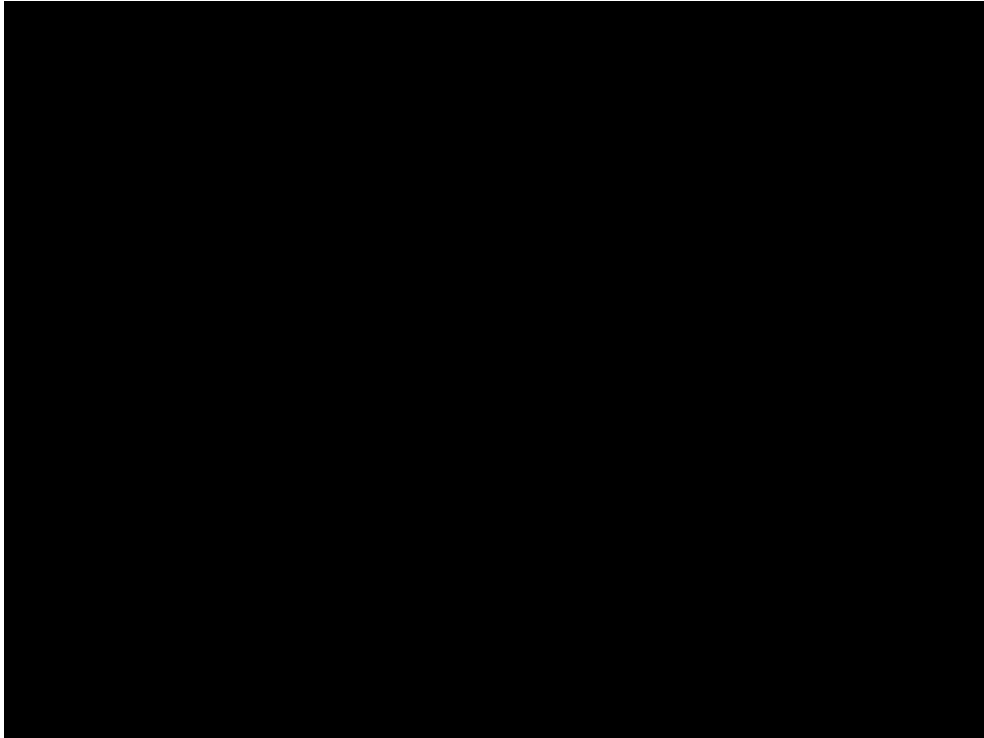

## Team 980 Weekly Zoom

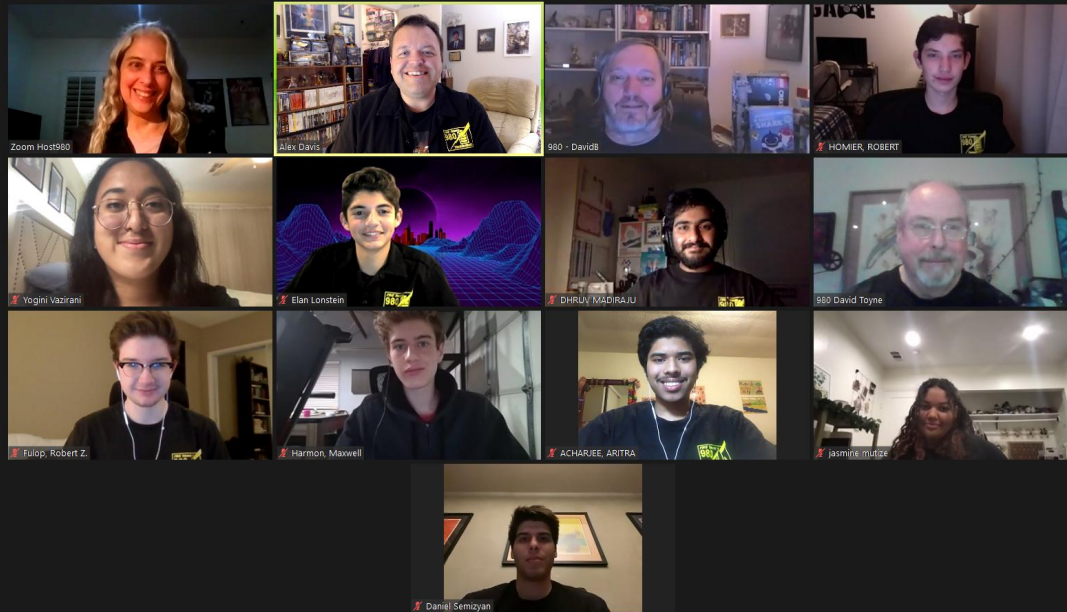

# 2021 @Home Challenge

**FIRST**  
INNOVATION CHALLENGE  
PRESENTED BY **Qualcomm**

### 2021 FIRST California Workshop Series: PRODUCT DEVELOPMENT + DESIGN THINKING

Identify the Opportunity	Generate Ideas	Evaluate Ideas & Filter	Determine Business Strategies	Develop the Idea	Product Trial
<ul style="list-style-type: none"> <li>Evaluate the Innovation Challenge Criteria</li> <li>Design Thinking - Empathy &amp; Define</li> <li>Problem Statement</li> <li>Intellectual Property Intro</li> </ul>	<ul style="list-style-type: none"> <li>Design Thinking - Ideate</li> <li>Brainstorming</li> <li>Diversity &amp; Inclusion of Ideas</li> </ul>	<ul style="list-style-type: none"> <li>Product Design Specification</li> <li>Concept Sketches</li> <li>Pugh Analysis Matrix</li> <li>Market Analysis</li> <li>SWOT Analysis</li> </ul>	<ul style="list-style-type: none"> <li>Strategy for Startups</li> <li>Product-Market Fit</li> <li>Value Proposition</li> <li>Innovation S-curve</li> <li>Prepare the Pitch</li> </ul>	<ul style="list-style-type: none"> <li>Design Thinking - Prototype</li> <li>Design Engineering</li> <li>Manufacturability &amp; Reliability</li> <li>Ergonomics &amp; User Experience</li> <li>Patents</li> </ul>	<ul style="list-style-type: none"> <li>Design Thinking - Test</li> <li>Test/Experiment Design</li> <li>A/B Testing</li> <li>Qualitative Testing</li> <li>Quantitative Testing</li> </ul>
Jan 9 <sup>th</sup> , 1-3pm	Jan 16 <sup>th</sup> , 10am-Noon	Jan 23 <sup>rd</sup> , 10am-Noon	Jan 30 <sup>th</sup> , 10am-Noon	Feb 6 <sup>th</sup> , 10am-Noon	Feb 20 <sup>th</sup> , 10am-Noon

Teams are also invited to join a *Pitch Party* planned in March. *FIRST* Regional Directors will reach out to teams directly with details.

<https://cafirst.org/product-development-design-thinking/>

**StressLess**

# OUR MENTORS

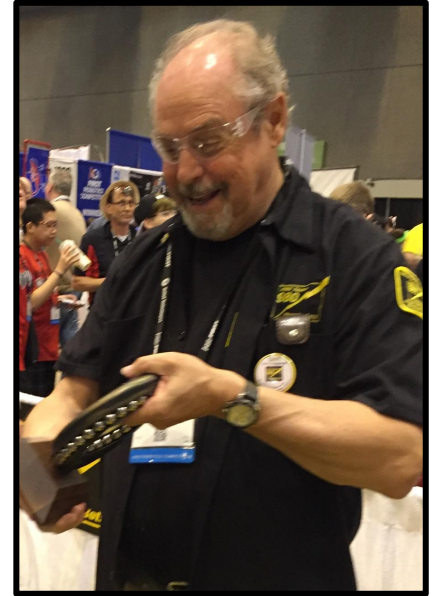
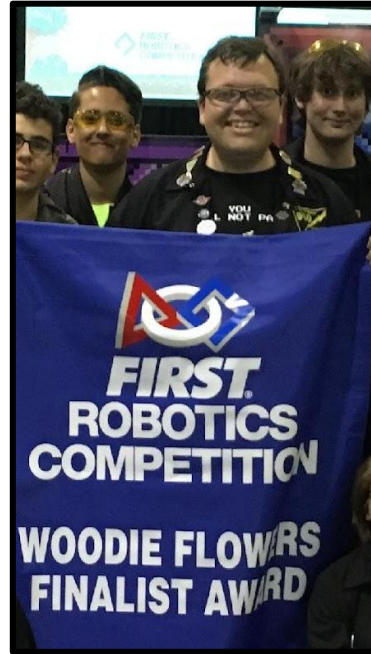

# OUR SPONSORS

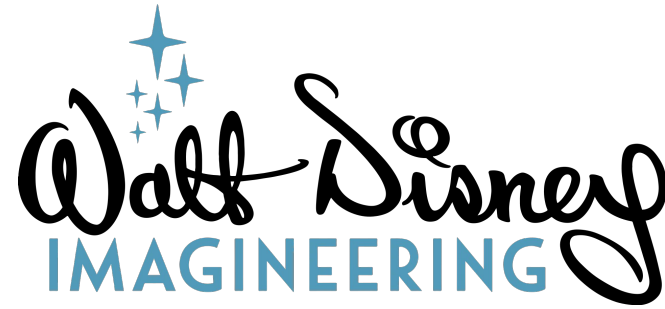
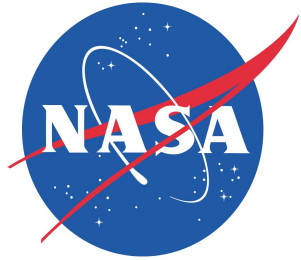

# WHAT'S NEXT FOR TEAM 980

- Expand the Pipeline
- Youth Robotics Center
- Training this year's rookies to be next year's leaders

